



Building Envelopes 101

Who is Building Professionals

Building Professionals is a Winnipeg-based family company that has been providing quality assurance, certification, training and consulting services for over three decades to the sustainable building industry

Overview

- What is the Building Envelope ?
- Importance of Building Envelope for Energy efficiency and durability
- Functions of the Building Envelope
- Code Requirements
- Perfect Wall / Roof / Below Grade
- Perfect Barriers vs Imperfect Barriers
- Air Barriers

Overview

- Vapour Barriers
- Insulation
- Water Resistive Barriers / Water Management
- Resources to learn more

What is the Building Envelope ?

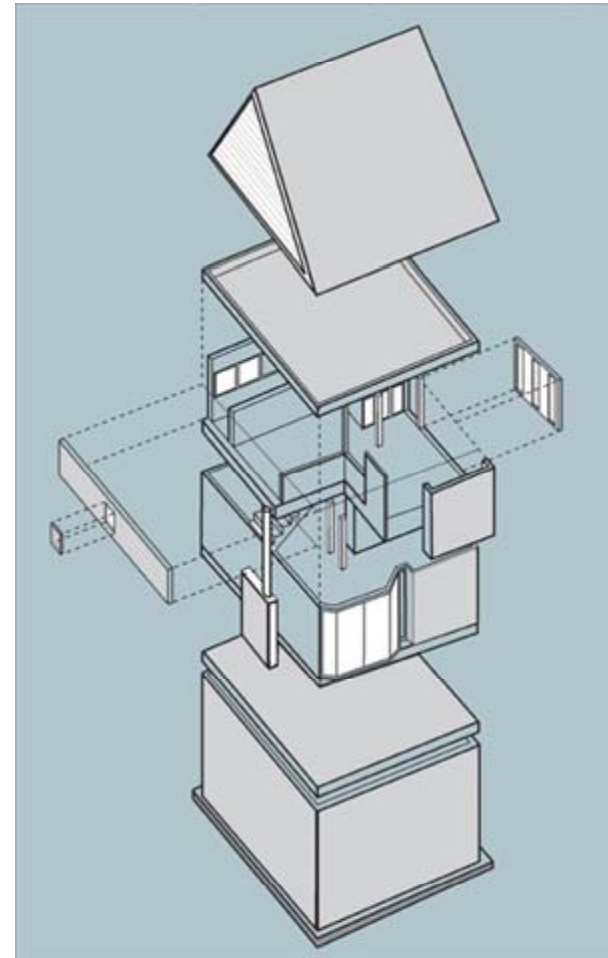

Importance of the Envelope ?

- Energy
- Durability
- Protection
- Fire
- Architecture
- Moisture Management
- Comfort

Function of the Building Envelope?

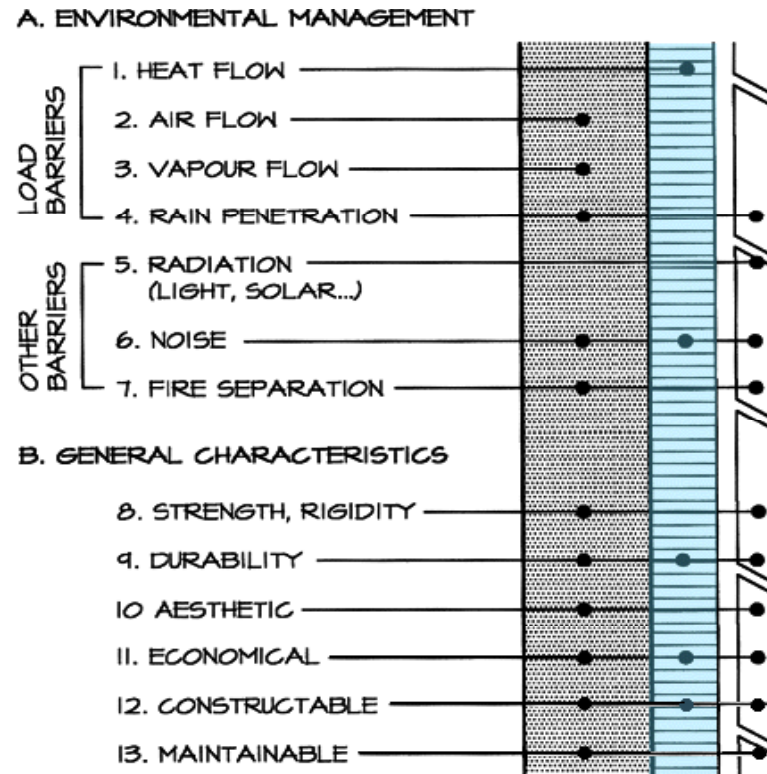

ENVELOPE REQUIREMENTS (PRIMARY FUNCTIONS)

Building Codes

Section 5.4. Air Leakage

5.4.1. Air Barrier Systems

5.4.1.1. Required Resistance to Air Leakage

(See Appendix A.)

1) Where a *building* component or assembly separates interior *conditioned space* from exterior space, interior space from the ground, or environmentally dissimilar interior spaces, the properties and position of the materials and components in those components or assemblies shall be such that they control air leakage or permit venting to the exterior so as to

- a) provide acceptable conditions for the *building* occupants,
- b) maintain appropriate conditions for the intended use of the *building*,
- c) minimize the accumulation of condensation in and the penetration of precipitation into the *building* component or assembly,
- d) control heat transfer to roofs where ice damming can occur,
- e) minimize the ingress of airborne radon from the ground with an aim to controlling the indoor radon concentration to an acceptable level, and
- f) not compromise the operation of *building* services.

2) Except as provided in Sentence (3), an *air barrier system* shall be installed to provide the principal resistance to air leakage.

3) An *air barrier system* is not required where it can be shown that uncontrolled air leakage will not adversely affect any of

- a) the health or safety of *building* users,
- b) the intended use of the *building*, or
- c) the operation of *building* services.

5.4.1.2.

Air Barrier System Properties

1) Except as provided in Sentence (2), materials intended to provide the principal resistance to air leakage shall

- a) have an air leakage characteristic not greater than $0.02 \text{ L}/(\text{s}\cdot\text{m}^2)$ measured at an air pressure difference of 75 Pa, or
- b) conform to CAN/ULC-S741, "Air Barrier Materials - Specification."

(See Appendix A.)

2) The air leakage limit specified in Sentence (1) is permitted to be increased where it can be shown that the higher rate of leakage will not adversely affect any of

- a) the health or safety of the *building* users,
- b) the intended use of the *building*, or
- c) the operation of *building* services.

(See Appendix A.)

3) The *air barrier system* shall be continuous

- a) across construction, control and expansion joints,
- b) across junctions between different *building* assemblies, and
- c) around penetrations through the *building* assembly.

4) The structural design of *air barrier systems* installed in assemblies subject to air pressure loads shall comply with Article 5.1.4.1. and Subsection 5.2.2.

Perfect Wall Concept

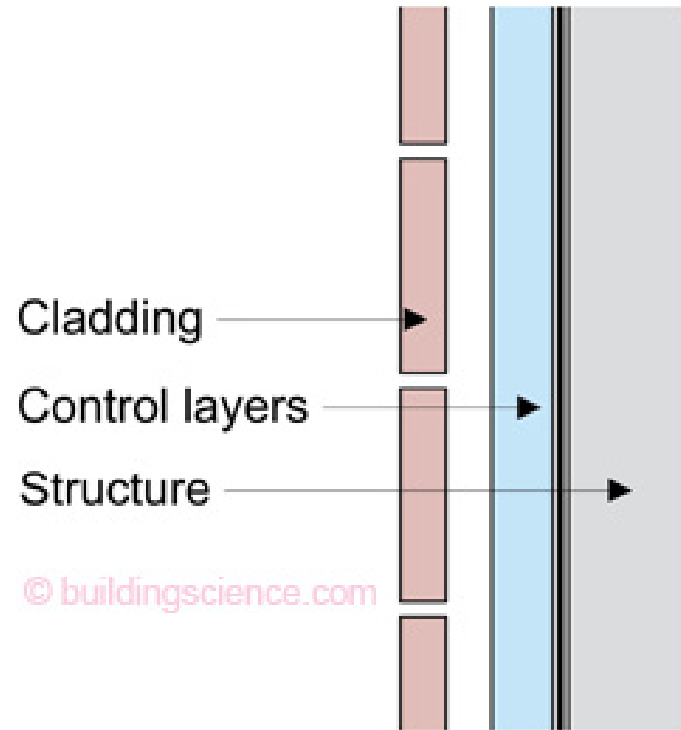
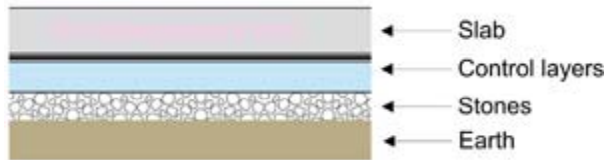

Perfect Wall Concept

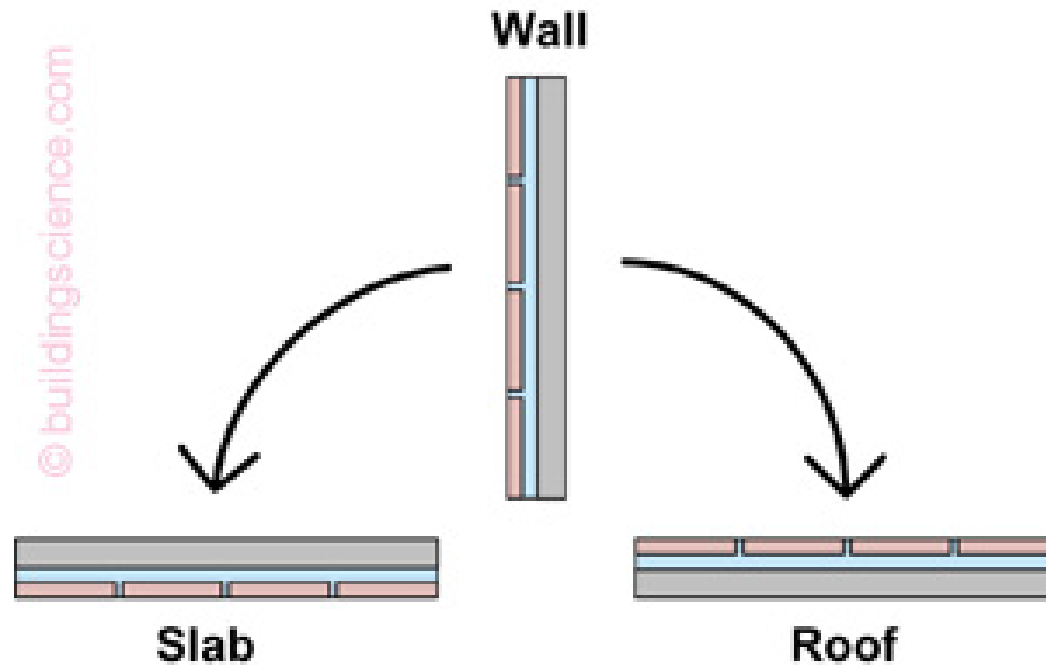

Perfect Wall Concept

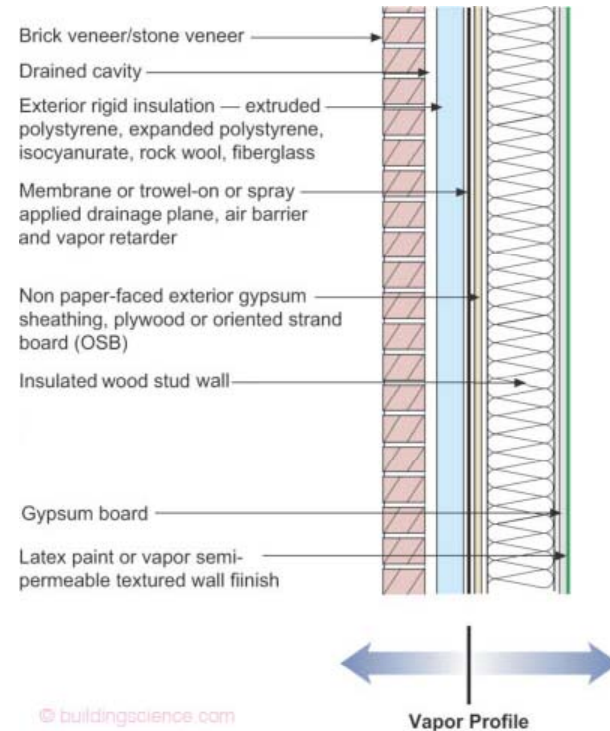
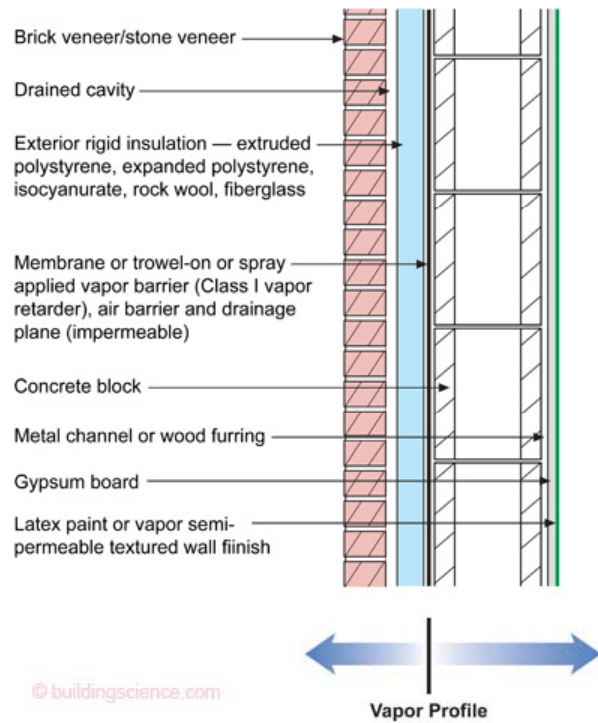

Types of Barriers

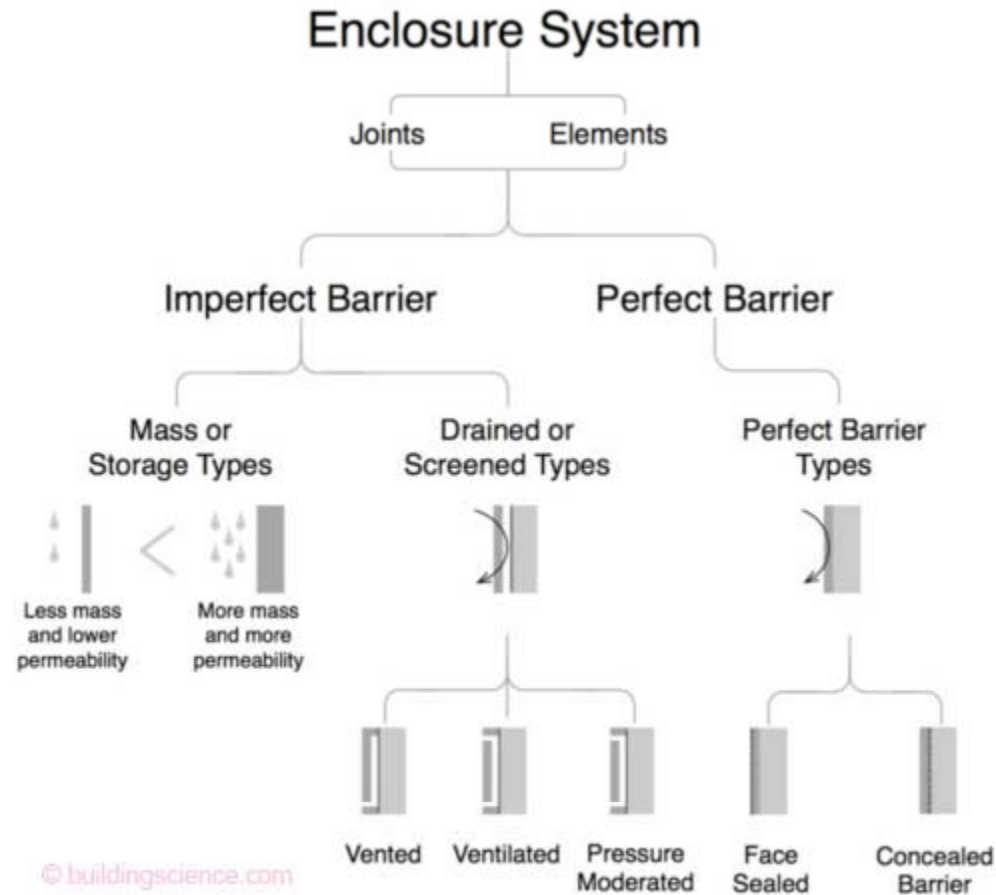

Notes: The categorization is based on actual behaviour, not necessarily design intent.

For the purposes of this classification system, the following definitions are necessary:

1. Drained: the large majority of the water that penetrates the screen is removed by gravity.
2. Cavity: a clear space or a filled space that facilitates gravity drainage and air flow and resists the lateral transfer of water (a capillary break).
3. Ventilated: allows a significant flow of air largely to promote drying by vapor movement.
4. Vented: allows some degree of water vapor diffusion through vent and redistribution within the cavity by air mixing and vapor diffusion.
5. Pressure-moderated: an approach that moderates air pressure differences across the screen. If perfect moderation is achieved, a theoretical condition, it is termed "pressure equalized"

Air Barriers

“Air Barriers cannot be dealt with without understanding that they are part of a wall assembly”

N.B. Hutcheon’s CBD-48 - Requirements for Exterior Walls

Air Barriers

Air leakage occurs through cracks and openings in windows, doors, walls, roof and voids/openings in the air barrier assembly between adjoining materials.

- Factors for a quality final air barrier assembly include:
 - design of building envelope
 - quality of materials
 - quality of workmanship
 - consideration of air pressure differences

Air Barriers

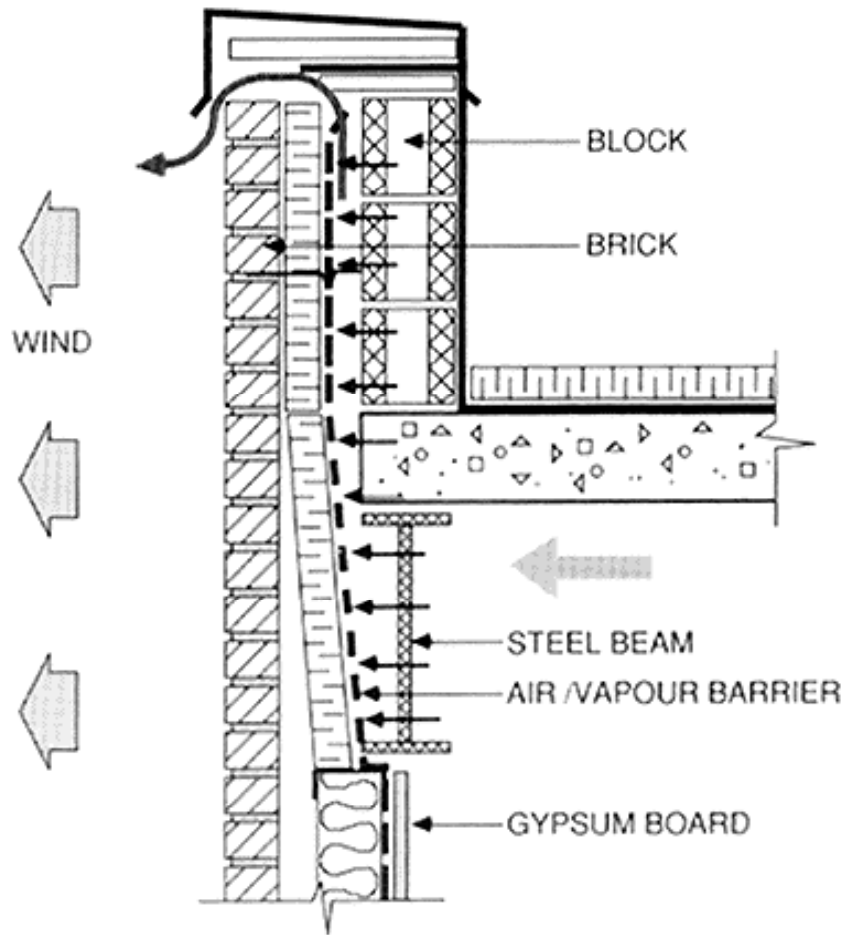

Air Barriers

PERFORMANCE REQUIREMENTS FOR AIR BARRIERS

What is an air barrier?

- Depends on whether you are talking about:
 - material
 - accessory
 - assembly
 - System
 - component

Air Barriers

PERFORMANCE REQUIREMENTS FOR AIR BARRIERS

What is an air barrier material?

- A material that has been designed to provide the primary function of controlling the movement of air through a building assembly. These materials are tested in accordance with ASTM E2178. ABAA requires an air permeance of less than:
 - 0.02 L/(s•m²) @ 75 Pa
 - 0.004 cfm/ft² @ 1.57 lb/ft²

Air Barriers

PERFORMANCE REQUIREMENTS FOR AIR BARRIERS

- The air barrier material is only one part of the wall assembly and will need to be designed in conjunction with insulation, cladding systems, structural systems, water-shedding layer and items that may penetrate the air tightness layer.

Air Barriers

PERFORMANCE REQUIREMENTS FOR AIR BARRIERS

What materials are classified as air barrier materials?

- Metal
- Smooth surface roofing membrane
- Modified bituminous self adhering membrane
- Extruded polystyrene: 1 1/2" or thicker
- Phenolic insulation board: 15/16" or thicker
- Foil back gypsum board: 1/2" or thicker
- Certain asphalt impregnated fiber board
- Certain fluid applied membranes
- Sealants (caulking)
- Plastic
- Glass
- Modified bituminous torch grade membrane
- Plywood sheathing (3/8" or thicker)
- Foil back urethane insulation: 1" or thicker
- Cement board: 1/2" or thicker
- Concrete
- Certain trowel applied modified asphalt emulsions
- Gypsum board (use moisture resistant board)
- Certain urethane insulation materials
- Certain foam insulation
- Certain mechanically fastened membranes/building wraps

Air Barriers

PERFORMANCE REQUIREMENTS FOR AIR BARRIERS

What materials are NOT classified as air barrier materials?

While not an all encompassing list, here is a list of materials that when tested would not meet the requirements of an air barrier material. Notice that a number of materials will be very dependent on the thickness of material.

- Plywood sheathing (less than 3/8" thick)
- Tempered hardboard
- Asphalt Saturated Felt Paper (15# and 30#)
- Plain fiberboard
- Vermiculite insulation
- Concrete masonry units (CMUs)
- Flakewood board
- Particle board
- Expanded polystyrene
- Glass fiber rigid insulation board
- Asphalt impregnated fiberboard
- Glass wool insulation
- Cellulose insulation
- Brick

Air Barriers

PERFORMANCE REQUIREMENTS FOR AIR BARRIERS

Air barriers can be:

- Vapor Permeable (high perm rating)
- Non-Vapor Permeable (provides function of a vapor barrier)
- Insulation (providing air, vapor and thermal protection)
- Water-resistive barriers

Air Barriers

PERFORMANCE REQUIREMENTS FOR AIR BARRIERS

ASTM 2178 – Material Air Permeance

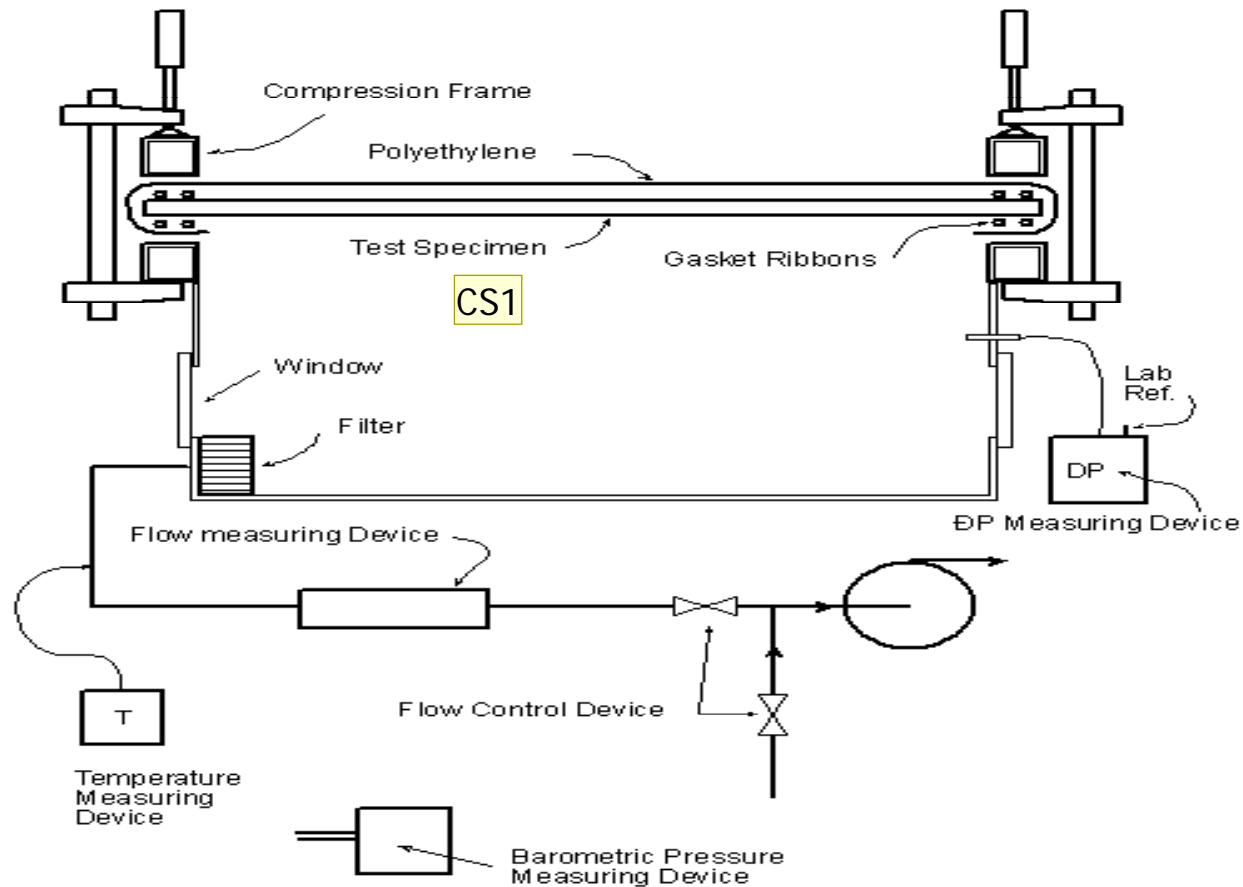

Slide 22

CS1

Lori, maybe we can have arrows showing air flow going through the sample.

Colin Szewaga, 5/23/2012

Air Barriers

PERFORMANCE REQUIREMENTS FOR AIR BARRIERS

ASTM 2178 – Material Air Permeance

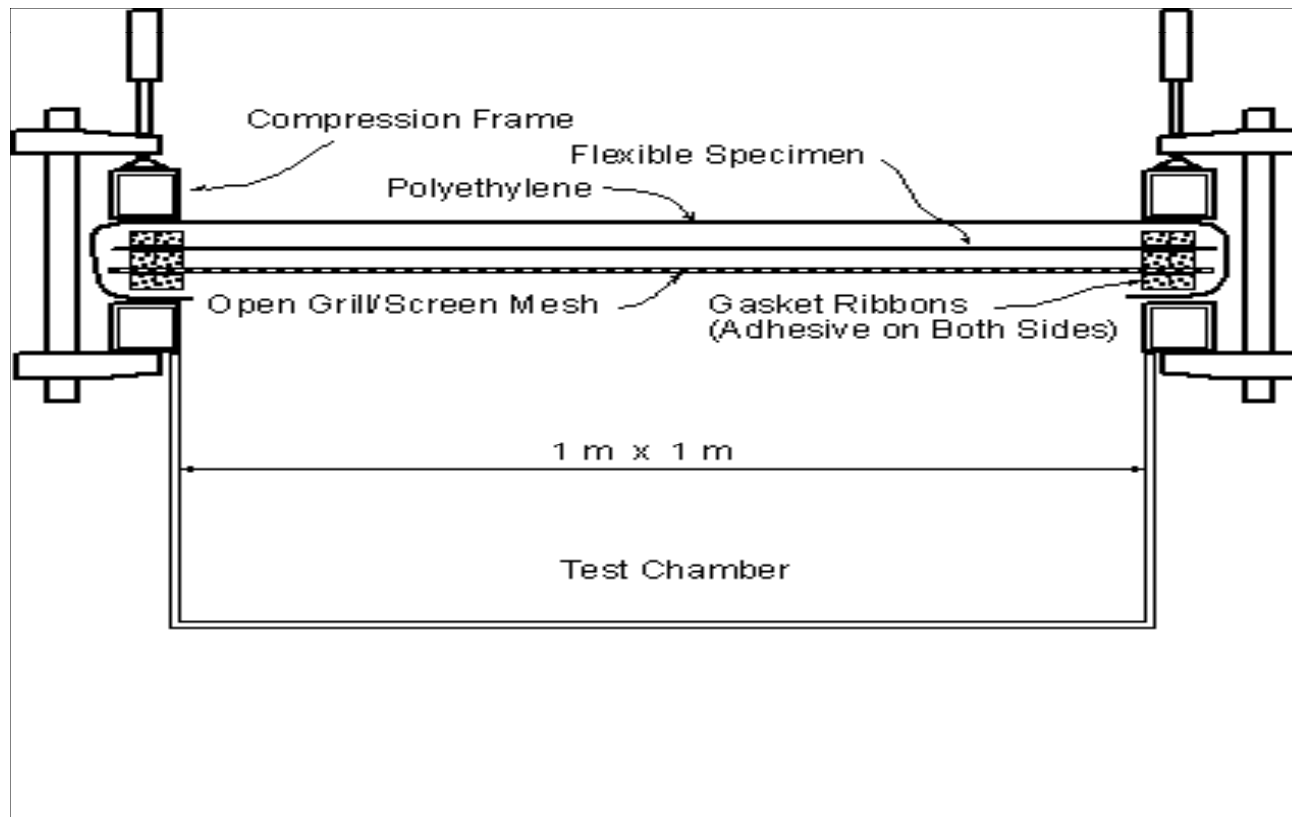

Air Barriers

What is an air barrier accessory

- Materials designated to maintain air tightness between air barrier materials, air barrier assemblies and air barrier components, to fasten them to the structure of the building, or both.
- Examples of accessories include sealants, transition materials, caulking, sheet metal, tapes and backer rod.

Air Barriers

PERFORMANCE REQUIREMENTS FOR AIR BARRIERS

What is an air barrier assembly?

- Combination of air barrier materials and air barrier accessories that are designated and designed within the environmental separator to act as a continuous barrier to the movement of air through the environmental separator

Air Barriers

PERFORMANCE REQUIREMENTS FOR AIR BARRIERS

Air barrier assembly key requirements that need to be considered:

- Continuity (most important / most difficult)
- Strength
- Durability
- (Im)permeability
- Compatibility

Air Barriers

PERFORMANCE REQUIREMENTS FOR AIR BARRIERS

Air barrier assembly requirements:

- The air barrier shall be joined in a continuous, air-tight and flexible manner to the air barrier material of adjacent systems, allowing for the relative movement of systems due to thermal and moisture variations and creep.

Air Barriers

PERFORMANCE REQUIREMENTS FOR AIR BARRIERS

- Transitions shall be made:
 - from foundations to walls
 - from walls to windows and/or doors
 - between different wall systems
 - from walls to roof
 - walls and roof over unconditioned spaces, and
 - walls, floors, and roof across construction control and expansion joints
 - between control, expansion and substrate joints
 - between dissimilar materials
 - from HVAC, pipe and similar penetrations to wall

Air Barriers

PERFORMANCE REQUIREMENTS FOR AIR BARRIERS

Air Barrier Assembly Requirements

- All CS2 penetrations of the air barrier and paths of air infiltration/exfiltration shall be made air-tight

CS2

Delete page

Colin Szewaga, 5/23/2012

Air Barriers

PERFORMANCE REQUIREMENTS FOR AIR BARRIERS

ASTM 2357 – Assembly Air Permeance

Specimen 1 - Opaque Wall

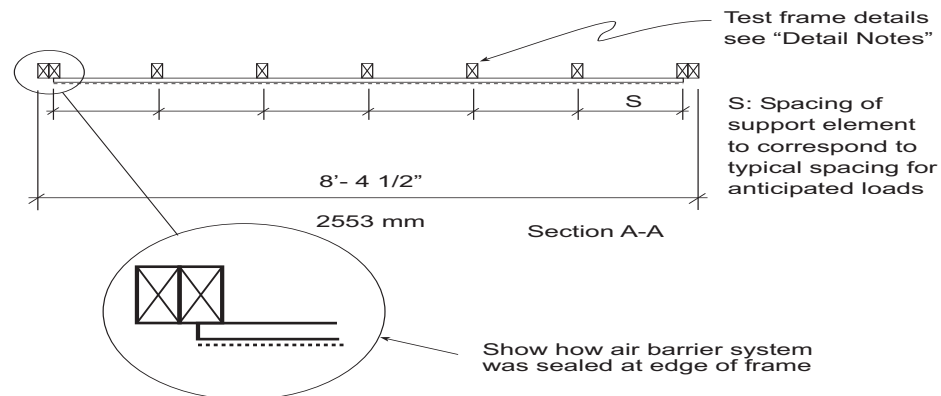
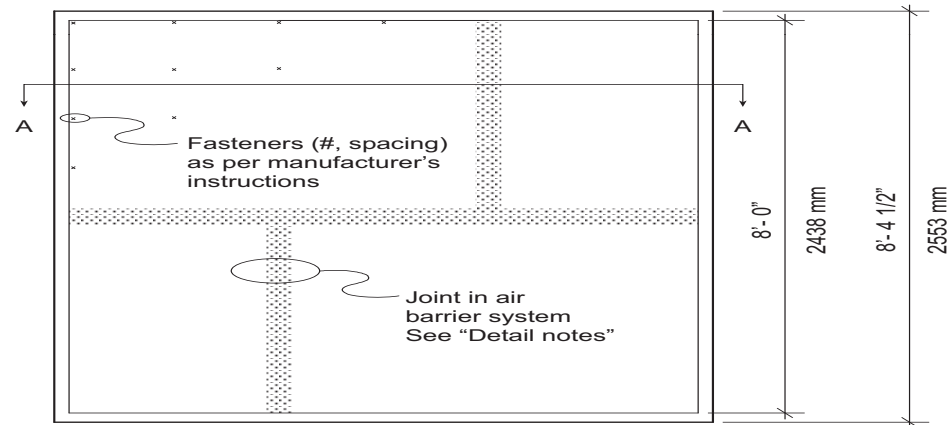

Air Barriers

PERFORMANCE REQUIREMENTS FOR AIR BARRIERS

ASTM 2357 – Assembly Air Permeance

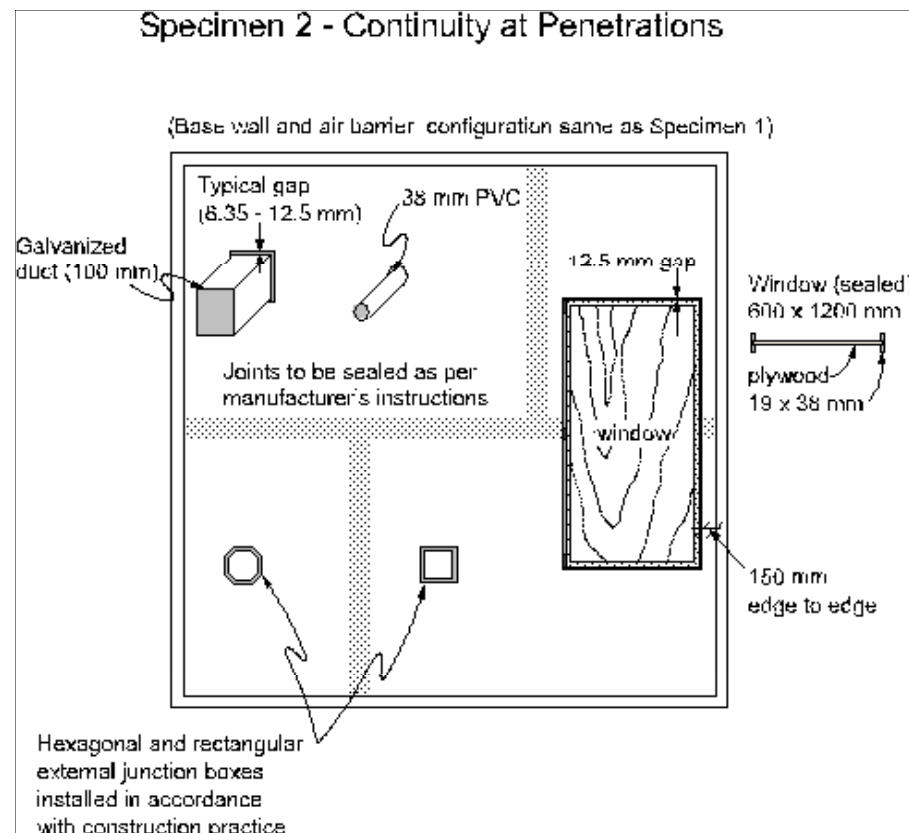

Air Barriers

PERFORMANCE REQUIREMENTS FOR AIR BARRIERS

ASTM 2357 – Assembly Air Permeance

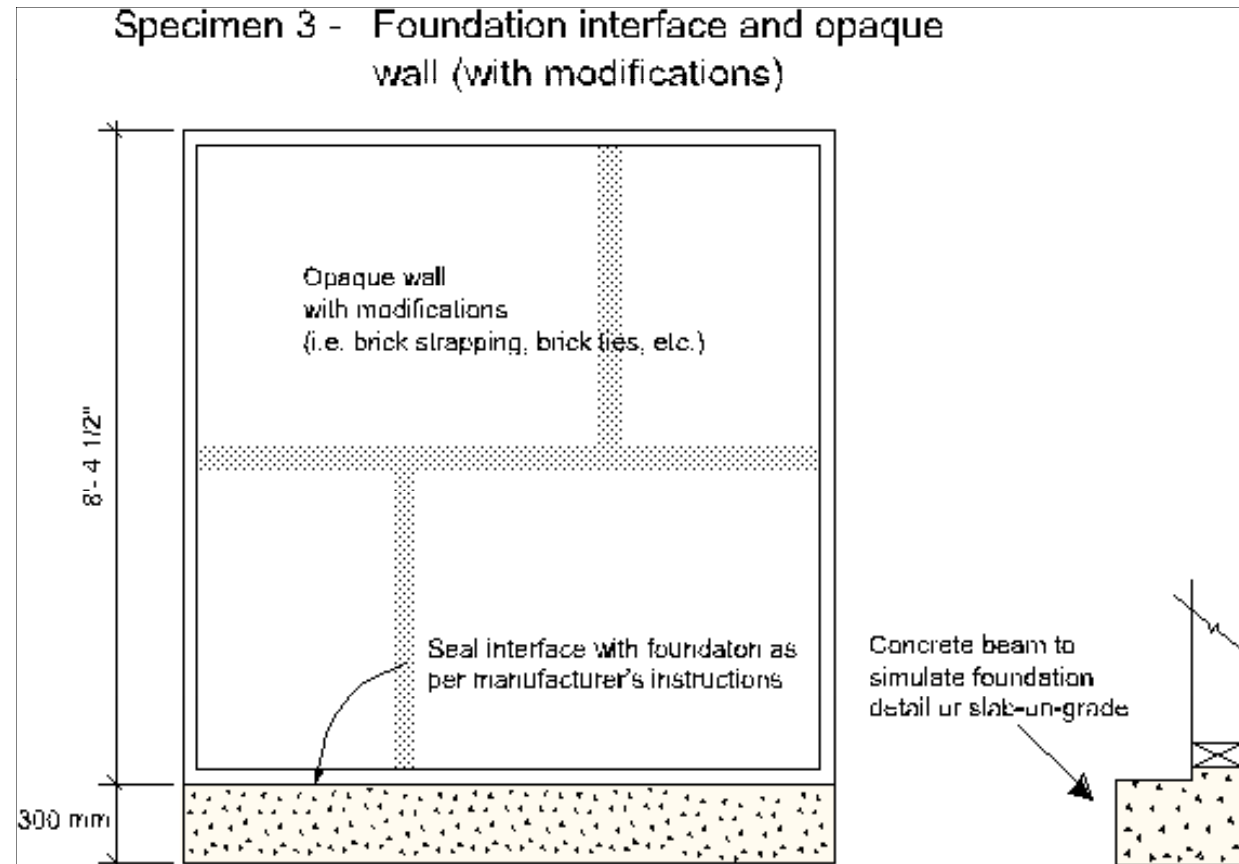

Air Barriers

PERFORMANCE REQUIREMENTS FOR AIR BARRIERS

Requirement	Requirement	Does it Meet 4 Key Criteria?
Air Permeance	0.004 cfm / sq. ft	2178 test report
Structural Strength	Withstand positive and negative loads	2357 test report
Continuous	Joints can be sealed and connections made to other components/details	Ask for 2357 test report and details for continuity and a listing of products that can be used to achieve continuity
Durable or Maintainable	Durable for life of building or maintainable	Ask for 2357 test report and history of product's use in the field.

Air Barriers

What is an air barrier component

- Pre-manufactured elements such as windows, doors and service elements.

Air Barriers

PERFORMANCE REQUIREMENTS FOR AIR BARRIERS

What is an air barrier system?

- Combination of air barrier assemblies and air barrier components, connected by air barrier accessories, that are designed to provide a continuous barrier to the movement of air through an environmental separator

Air Barriers

PERFORMANCE REQUIREMENTS FOR AIR BARRIERS

What is an air barrier system?

- The combination of the Air Barrier Assemblies and other building components (such as windows, roof, etc) to complete the plane of air tightness in the building assembly between different environments.

Air Barriers

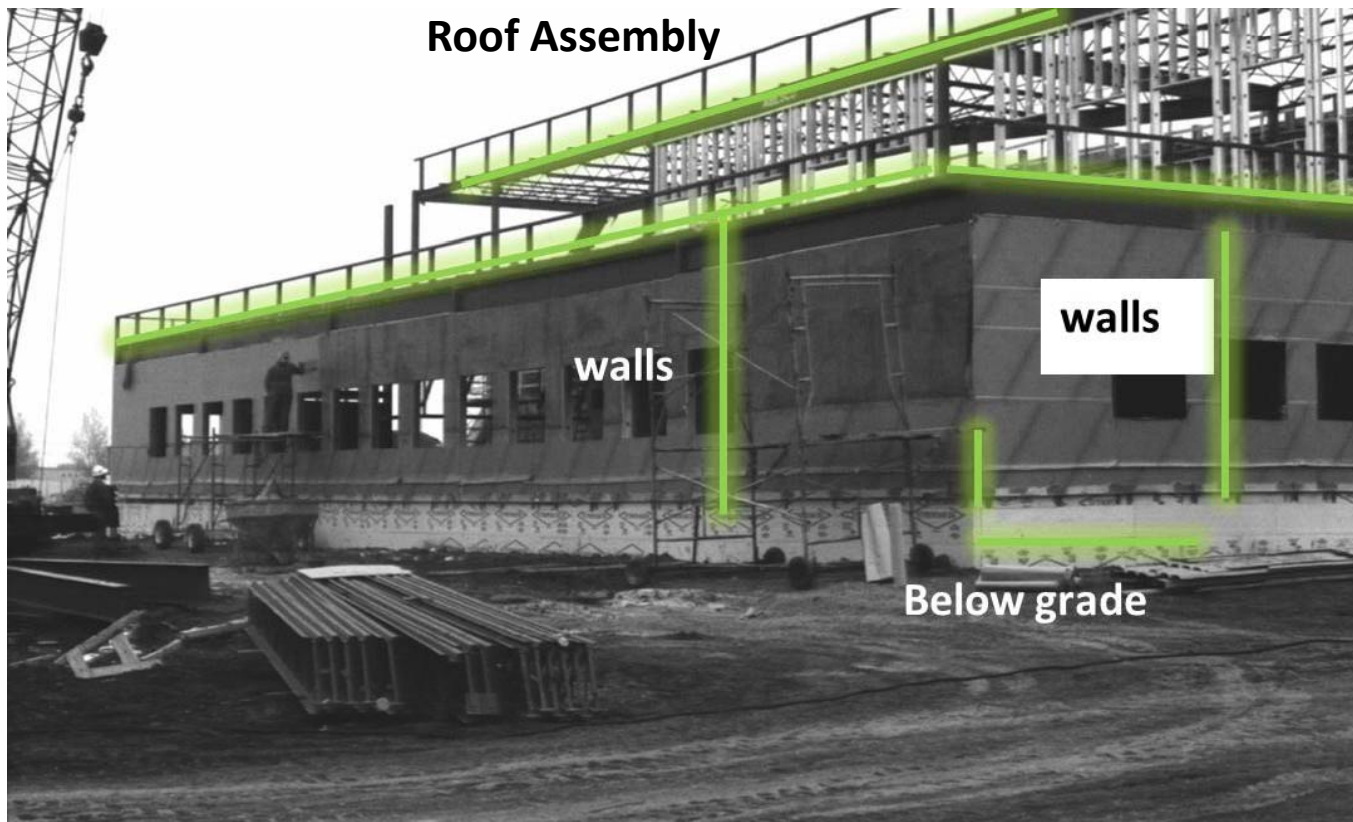

Air Barriers

COMMON DESIGN CONSIDERATIONS



Air Barriers

COMMON DESIGN CONSIDERATIONS

Considerations: General

- Type of building
- Expected service life of building
- Climate region
- Intended or resultant interior conditions
- Type of construction
- Type of building enclosure system



Air Barriers

COMMON DESIGN CONSIDERATIONS

Considerations: Load Capacities

- High rise or low rise
- High end or low end
- Structural framing system
- Climate zones within the building

Air Barriers

COMMON DESIGN CONSIDERATIONS

Considerations: Durability

- **One Year Buildings: Condos built by project specific LLC's**
- **Twenty to Thirty Year Buildings: Rentals**
- **Fifty Year Buildings: Government housing and state college or university dormitories**
- **One Hundred Year Buildings: Dormitories at institutional private schools**

Air Barriers

COMMON DESIGN CONSIDERATIONS

Considerations: Load Capacities

- Heating and cooling needs
- Moisture loads of climate region
- Wind loads
- Solar heat loads
- Local building code requirements

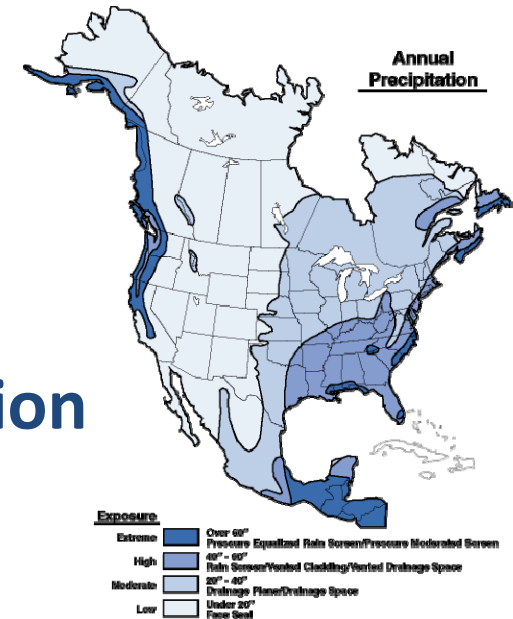

Air Barriers

COMMON DESIGN CONSIDERATIONS

Considerations: Moisture Related Loads

- Moisture loads due to occupancy rate
- Ventilated or non-ventilated
- HVAC System
- Dehumidified?
- Humidified?

Air Barriers

COMMON DESIGN CONSIDERATIONS

Considerations: Wall Type

- Wood framed?
- CMU framed?
- LGMF Framed?
- Steel framed?
- Concrete framed?

Air Barriers

COMMON DESIGN CONSIDERATIONS

Considerations: Moisture Loads

- Hygrothermal performance of components
- Hygrothermal performance of assembly
- Durability of components
- Solar heat gain / reflectivity of veneer layer

Air Barriers

COMMON DESIGN CONSIDERATIONS

Material Selection:

Properties of the air barrier material

Compatibility with other BE components

Adhesion / fastening to substrate

In service loads and stresses

Air Barriers

COMMON DESIGN CONSIDERATIONS

- Continuity Issues (Details)
 - Roof / Wall
 - Foundation / Wall
 - Window/Wall
 - Change in substrate
 - Expansion Joints
 - Floor to Floor

Air Barriers

COMMON DESIGN CONSIDERATIONS

Specifications

- Performance Based
- Separate Section for Air Barriers
- Relationships to others sections that impact air barrier installation
- Pre-construction Meetings
- Mock-up's
- Quality Assurance – Air Barrier Sub-trade Qualifications
- Testing/Verification Requirements

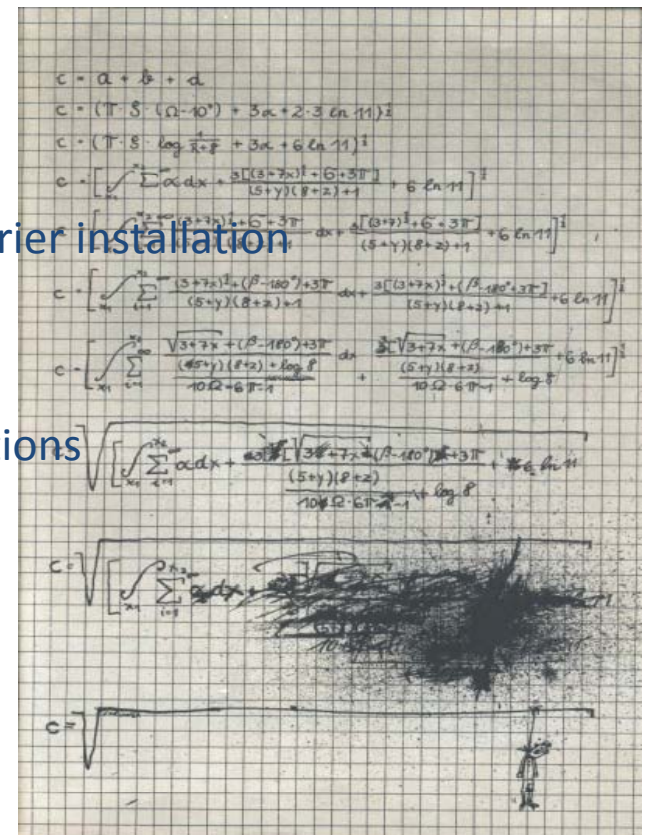

Air Barriers

COMMON INSTALLATION CONSIDERATIONS



Air Barriers

COMMON INSTALLATION CONSIDERATIONS

Cooperative Approach

- Pre-construction meetings with all related trades (windows, foundation, roof, mason, drywaller, etc)
- Sequencing to allow for continuity
- Understanding of connections and responsibilities
- Shop drawings
- On-site quality control measures
- 3rd party testing

Air Barriers

COMMON INSTALLATION CONSIDERATIONS

Qualified Air Barrier Sub-trade

- ABAA Accredited Contractor
- Trained and Certified Installers
- On-site process for testing, inspection and documentation
- Understanding of issues

Air Barriers

COMMON INSTALLATION CONSIDERATIONS

Substrate Preparation

- Typically not understood by responsible trade in request to condition for air barrier application
- Detailing required prior to air barrier application

Air Barriers

COMMON INSTALLATION CONSIDERATIONS

Substrate Preparation



Air Barriers

COMMON INSTALLATION CONSIDERATIONS

On-site QA/QC

- Trades testing and inspection (visual/adhesion, thickness, density, etc)
- 3rd party testing and inspection (visual, adhesion, thickness, density, air leakage)

Vapour Barriers

Vapour Barriers

- Air Barriers vs. Vapor Barriers
 - Vapor barriers can also be air barriers
 - Old (and sometimes recent) literature confuse or combine functions of air barriers and vapor barriers
 - Difference (air/vapor) most common building science question

Vapour Barriers

- Vapor Barriers
 - Simply reduce water vapor diffusion
 - Must be installed to cover most (but not all) of the area
 - Used when an assembly “would be adversely affected by condensation”

Vapour Barriers

- For years designers taught major requirement for insulated walls
- Graduated in 1960's to "continuous vapor barrier"
- Led to "air/vapor barrier"
- Did not work – had to go back to basic principals

Vapour Barriers

- Basic principals
 - Vapor barrier separates high vapor pressure from low
 - Important to be continuous, but not required, even by code
 - Does not have to be perfectly continuous
 - Unsealed laps, minor holes or cuts are not significant
 - Must be located on warm side of insulation

Vapour Barriers

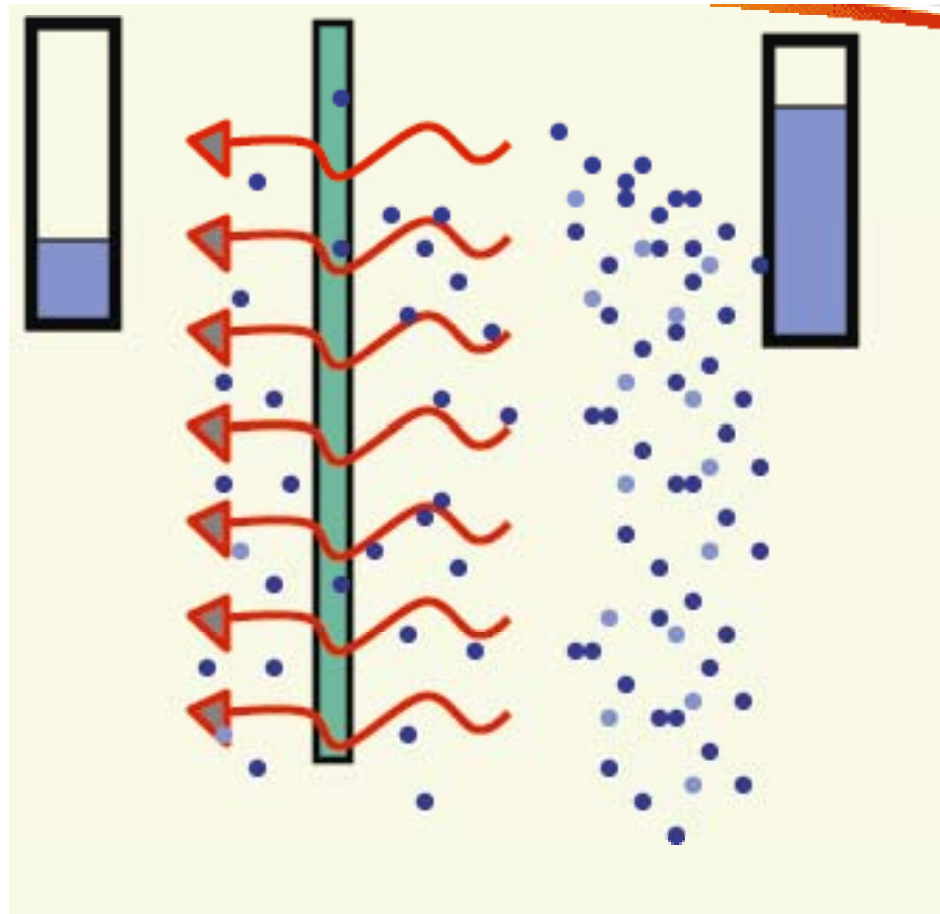

Vapour Barriers

- Vapor diffusion control has:
 - Calculation procedures
 - Regulatory requirements
 - Materials standards
 - Performance testing procedures
 - etc

Vapour Barriers

- Vapor diffusion control
 - Rate of vapor diffusion depends on:
 - Water vapor pressure difference
 - Resistance of the material to water vapor diffusion

Vapour Barriers

- Vapor diffusion control
 - Water vapor diffuses through all materials – only rate of diffusion varies
 - Vapor barrier retards or limits the rate of water vapor diffusion to a set limit
 - Moisture diffusion control property called “water vapor permeance”

Vapour Barriers

- Vapor diffusion control
 - Water vapor permeance expressed as:
 - weight of moisture that diffuses over a given area over a specific period of time at a vapor pressure difference
 - Example $wvp_{10} = 10$ nanograms of moisture to pass through one square meter of material per second when there is one pascal of water vapor pressure

Vapour Barriers

- Vapor diffusion control
 - Vapor barrier normally is
 - 1 perm = 60 /ng/Pa·s·m²

Vapour Barriers

- Vapor diffusion control
 - Example
 - 1 m² material with 5/ng/Pa·s·m²
 - Interior 21°C 30% R.H.
 - Sheathing - 20°C
 - One month time frame
 - Produces
 - 6 grams of solid water (frost)

Vapour Barriers

- More precise definition of vapor barrier
 - “A vapor impermeable layer that resists the diffusion of water vapor under action of a difference in vapor pressure”
 - Implies that diffusion is prime cause of moisture problems
 - More accurate to say vapor diffusion never initiates a problem

Insulation

- Two types
 - Air
 - Something better than air

Insulation

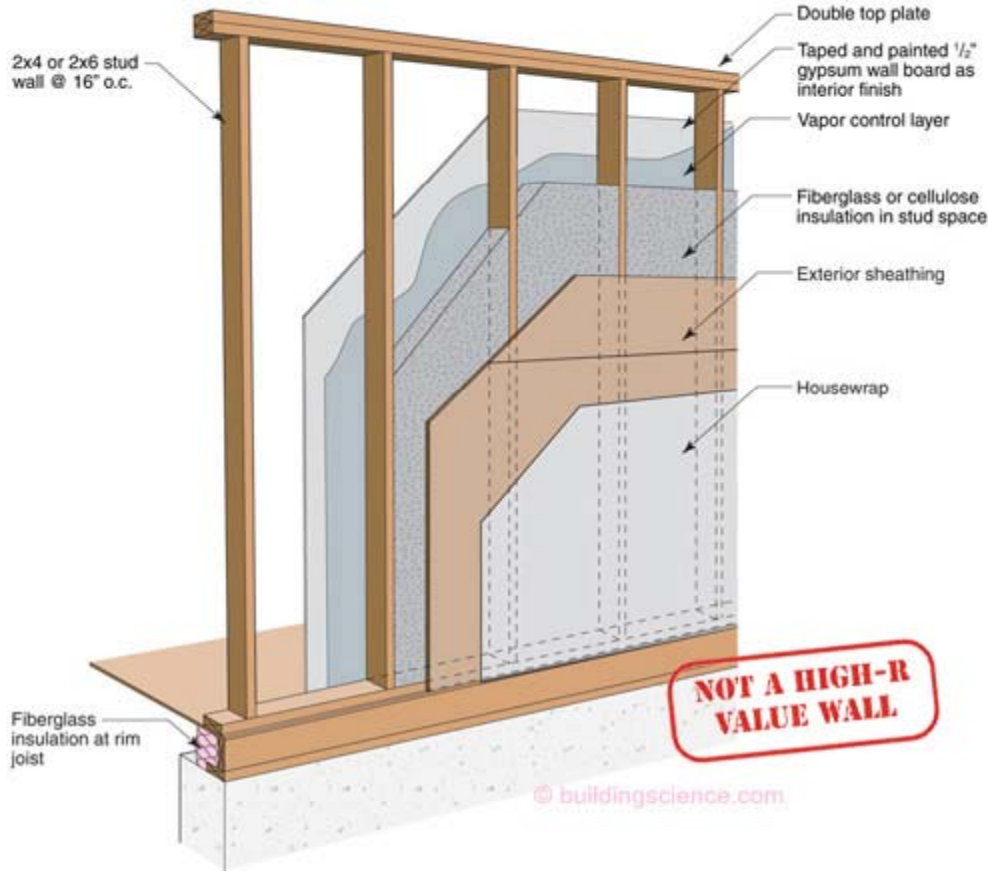

Insulation

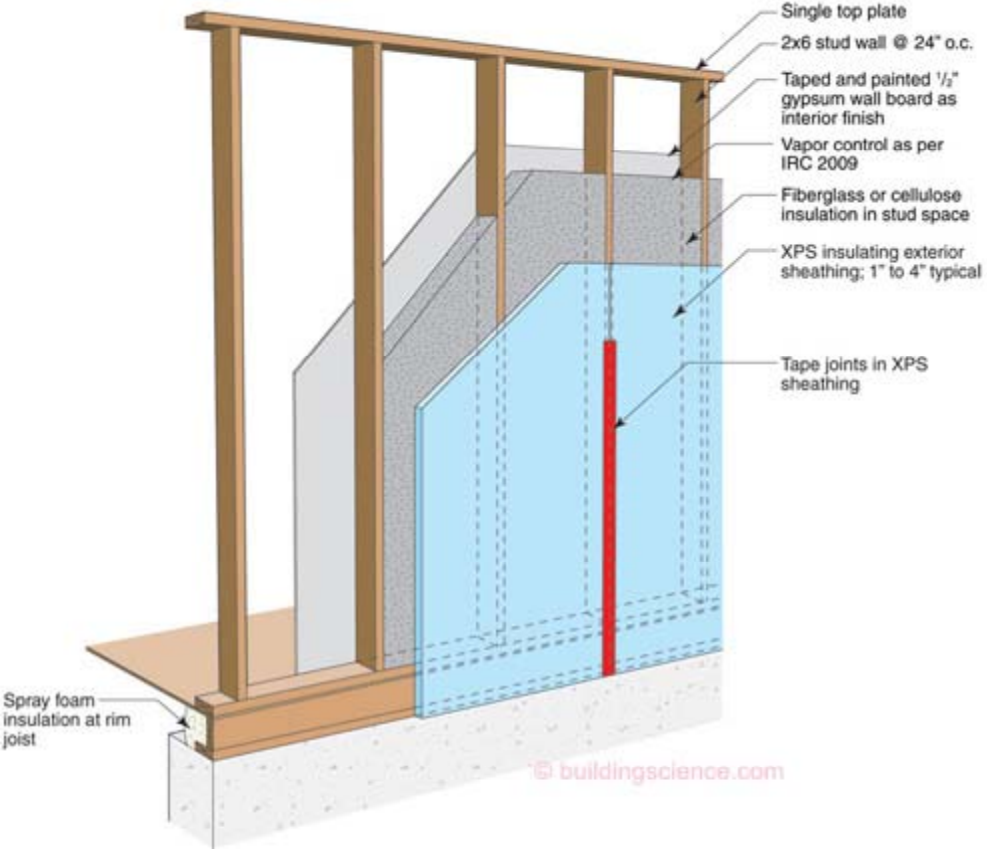

Insulation

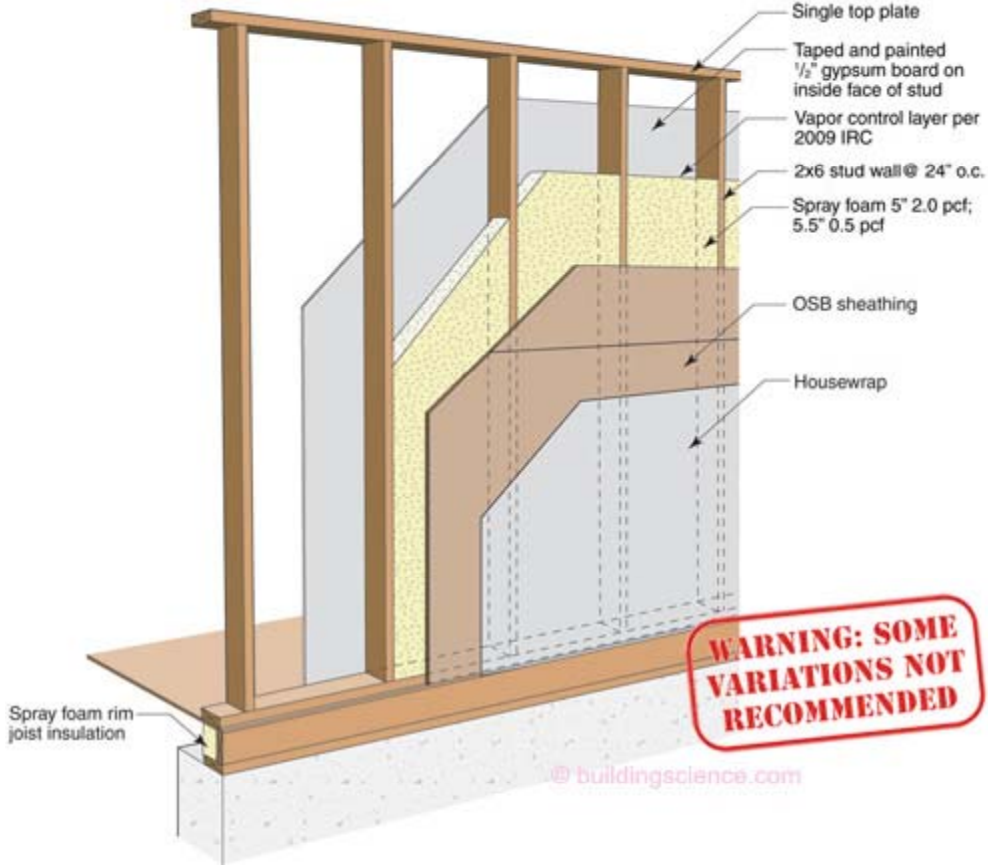

Insulation

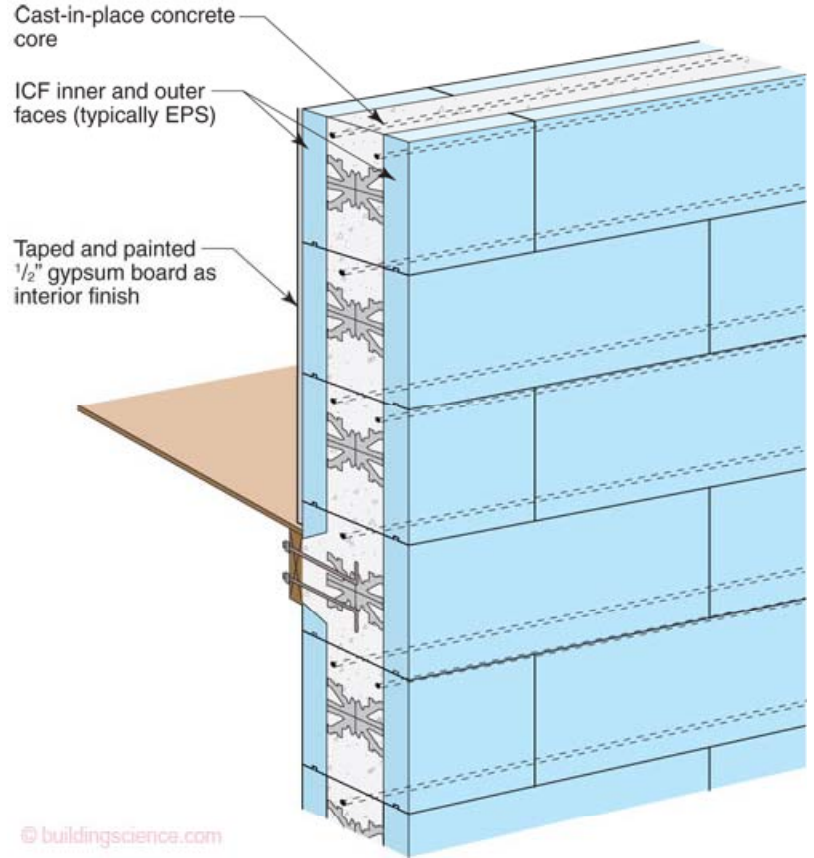
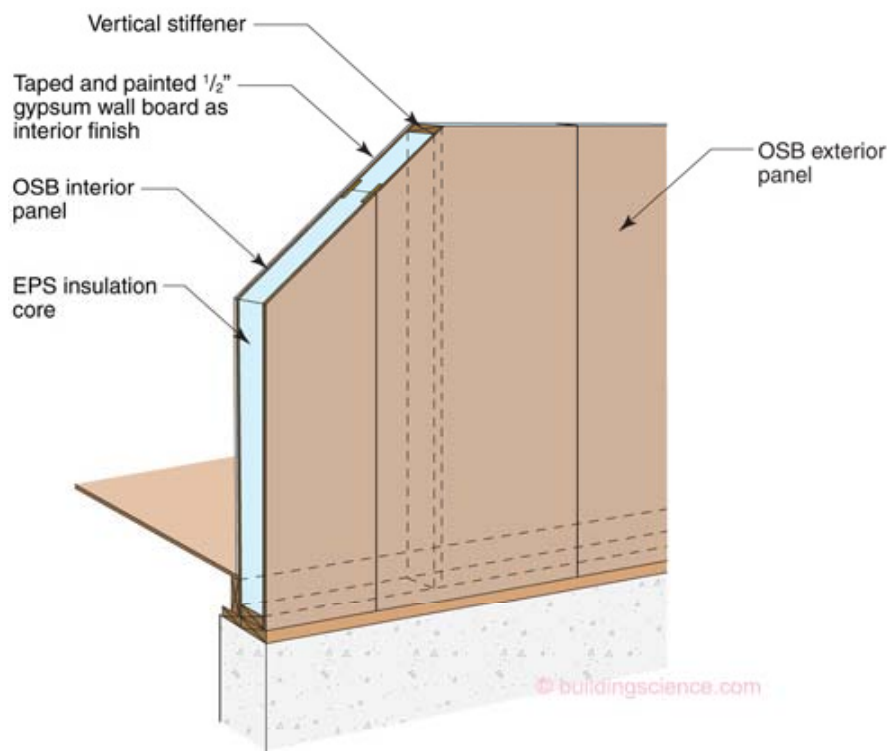

Insulation

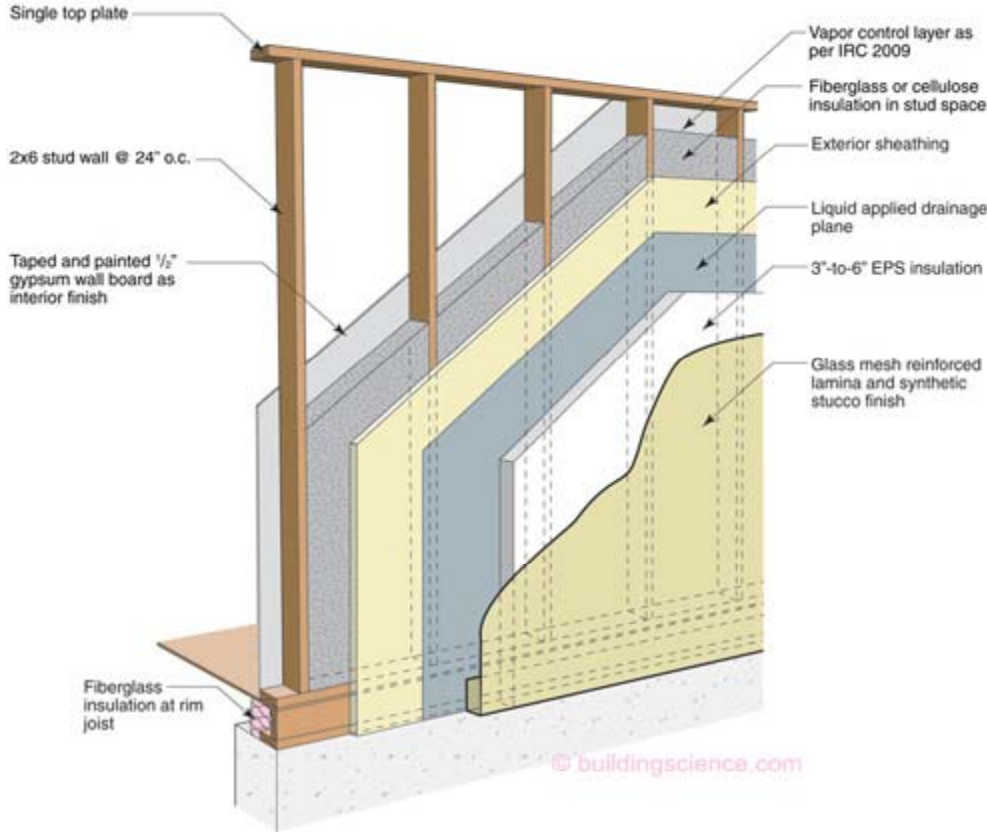

Water Management

- Water Management
- Water Resistive Barriers
- Flashings

Water Management

- 4 D's
 - Deflect
 - Drainage
 - Drying
 - durable

Water Management

- Water Resistive Barriers

Water Resistive Barrier

Thin Membrane Layer

- Typically 5 to 15 mils thick (0.005 to 0.015 in. or 0.13 to 0.38 mm)
- Variety of Widths and Lengths

Material Construction

- Polyolefin-based (plastic)
- Spun-bonded (fibers)
- Cross-woven (tapes)
- Films (sheets)-multiple integration of construct processes

Water Resistive Barrier

Primary Functions

Water Resistance

- Hydrophobic, Designed to Resist Bulk Water Penetration
- Secondary Weather Membrane
- Water Control
 - Deflect Water
 - Deflect Water & Channel Vertical Water Flow

Water Resistive Barrier

Primary Functions

Diffusion Control

- Membrane permeabilities that offer compatibility with wall & cladding systems wetting/drying characteristics and local environment.

Water Resistive Barrier

Primary Functions

Air Control

- All housewraps function as air retarders.
- Some housewraps may also meet the requirement for an Air Barrier Material (0.004 cfm/ft² @ 1.57 psf [0.02 L/s·m² @ 75 Pa]) - reducing air permeance.
- Housewraps that qualify as air barrier materials must be installed in strict accordance with the manufacturer's instructions in order to perform as required.

Water Resistive Barrier

Secondary Functions

Face of Chamber for Ventilation

- Three dimensional constructions combined with flat sheet rolled goods provide air exchange

Face of Chamber for Screen Pressure Moderation

- Housewrap is an integral component to the success of a Pressure Equalized Air Barrier design

Water Resistive Barrier

Air Flow Barrier

- **Wind Wash Barriers-Minnesota (code requirements)**
 - Reduce convective wind washing against sheathings
 - Reduce exterior air infiltration into stud wall cavity
- **Air Barrier Assembly**
 - Reduce Drafts
 - Increase Comfort
 - Reduce Energy Use
 - Non-conditioned air entering/exiting conditioned wall cavity
 - Air entrained moisture damping insulation, reducing effective R-value of insulation

Water Resistive Barrier

Water Flow Barrier

- Water Resistance

-Hydrophobic, not absorbing transferring bulk water through the thinness of the material

- Keeping Wall Cavity Dry
- Reducing Potential for Rot/Degradation

Water Resistive Barrier

Water Vapor Diffusion

- Water vapor permeable
- Keeps wall cavity dry
 - Numerous permeance ranges allow selection to accommodate service conditions
- Reduces Wetting Potential
- Reduces Condensation Potential
 - Allows vapor to flow in a drying direction, thereby reducing wetting according to service conditions or desired results

Water Resistive Barrier

Durability

-Resist

- Handling Damage, Job Site and Installation
- Wind Damage During Construction
- UV Degradation to Membrane
- Common Jobsite Chemicals
- Expansion/Contraction Damage to Membrane caused by wetting, drying, heating, cooling.



Housewrap

Housewrap Standards (Chart is part of packet)

Specification Standard	Test Standard	Performance Property	Specimen size	Test Procedure	Test Results	Notes
	ASTM E 2178	Air Permeance of Materials	AR membrane sample 3.3 ft x 3.3ft (1m x 1m)	Air Leakage measured @ 0.52, 1.04, 1.57, 2.09, 3.13, 6.27 psf (25,50,75,100, 150, & 300 Pa)		Control Sample:1/2" gypsum board air leakage not exceeding 0.004 cfm/ft ² @ 1.57 psf (0.02 L/s/m ² @ 75 Pa)
				Air Leakage re-measured at 2.09, 1.57 & 1.04 psf (100,75, & 50 Pa) to determine if psf/Pa affected Specimen	Air Leakage thru AR material reported as cfm/ft ² @1.57psf (L/s/m ² @75Pa)	
ASTM E 1677	Type 1: WRB/AR Type II:AR	Standard Specification for Air Retarder (AR) Material or System for Low-Rise Framed Building Walls				Two Classifications: Type I , water resistant AR membrane for buildings made of materials affected by moisture Type II , AR membrane for buildings made of materials "not" affected by moisture
ASTM E 1677	ASTM E 283	Rate of Air Leakage	Wall Assembly: -8'x 8'wall (2438 X 2438 mm) -2 x 4 stud @ 16"o.c. (50 X 102 mm @ 406 mm) -Solid sheathing noted -Specimen sealed to vertical edges and if noted by mfg., to top & bottom edges -1 electrical receptor installed	Determine Air Leakage Rate by maintaining for 1 minute a positive/negative pressure @ 1.57 psf or 75 Pa (25 mph)	Air Leakage: =0.06 cfm/ft ² @ 1.57psf 0.3 L/s·m ² @ 75 Pa)	
ASTM E 1677	ASTM E 330	Membrane Structural Integrity	-Simulate lap siding by installing 1" x 1" (25 mm X 25 mm) wood strips horizontally, 9" (228 mm) vertically -Simulate brick veneer by installing brick ties 16" x 16" (406 mm X 406 mm) grid to field wall assembly	Sustain 10.45 psf at 500 Pa (65 mph) for 1 hour each direction, negative positive pressure testing	Observe and measure deformation, and nature of distress and failure of membrane.	Follow structural integrity E 330 testing with specimen retested with E 283 for 1 min. at each 1.04, 1.30, 1.57, 1.82 & 2.09 psf (50, 62, 75, 87 & 100 Pa) to verify air leakage performance
ASTM E 1677	ASTM E 331	Water Penetration of Assemblies		Water Resistance: 0.11 in. H ₂ O @ 0.56 psf or 2.79 mm H ₂ O @ 27 Pa (15 mph) for 15 min.		Type I Water-Resistant Membrane
ASTM E 1677	ASTM E 96	Water Vapor Permeance of Materials	See ICC-ES Acceptance Criteria AC38	Procedure A: Desiccant Method -Test chamber @ 73.4°F ± 2°F (23°C ± 2°C) & R/H @ 50 ± 2%	E 1677 does not provide a minimum or maximum permeance value	AC 38 Acceptance Criteria for Water-Resistive Barriers: Procedure A, both control and aged specimens ≥ 5 perms (35 g/ m ² /24 hrs)

Flashings and Integration with AB/WRB

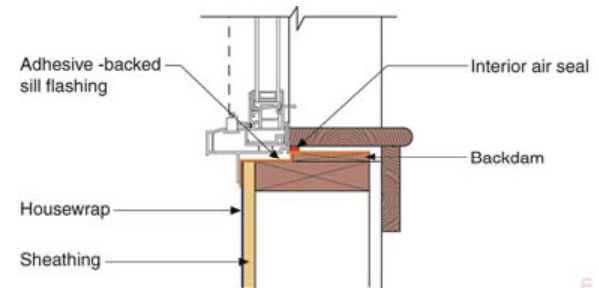
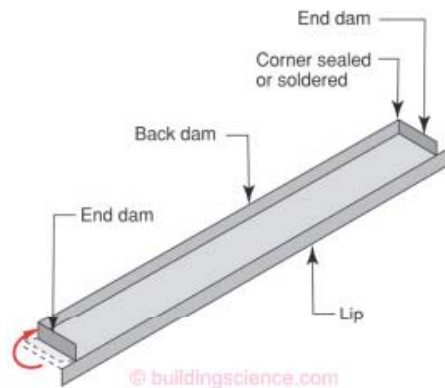
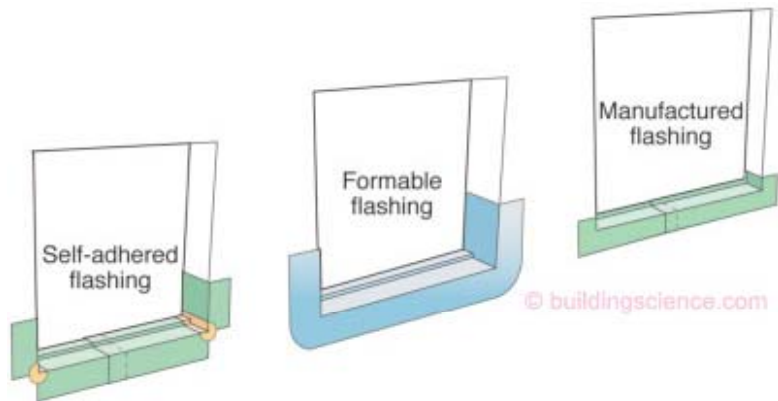

A strip of wood nailed at the back of the rough opening sill forms a dam to prevent water from draining into the interior.

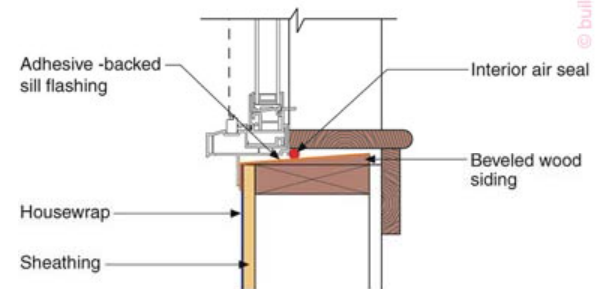

A piece of wood bevel siding nailed over the sill to create positive drainage toward the exterior is even better. Note that the rough opening needs to be enlarged to account for this and tapered shims in the opposite direction of the slope may be required.

Flashings and Integration with AB/WRB

EPA Indoor airPLUS | MOISTURE CONTROL 1.6
www.epa.gov/indoorairplus
STEPS 1 & 2 OF 5

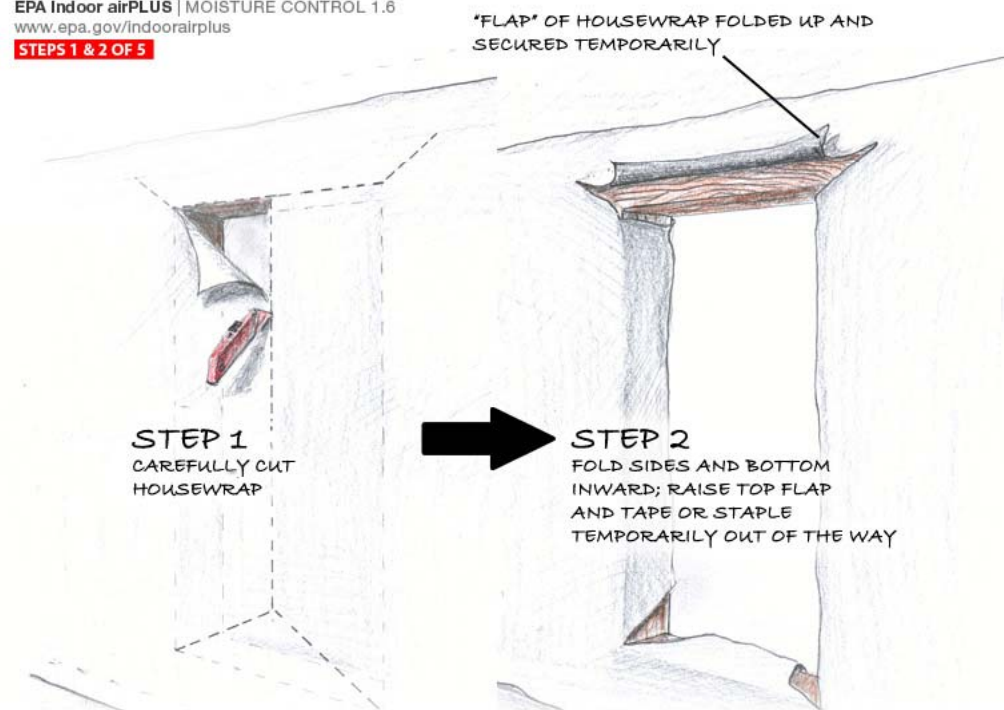

WINDOW FLASHING - HOUSEWRAP DRAINAGE PLANE - **5 STEPS**
STEPS 1 AND 2 - CUTTING AND FOLDING HOUSEWRAP

Flashings and Integration with AB/WRB

EPA Indoor airPLUS | MOISTURE CONTROL 1.6
www.epa.gov/indoorairplus

STEP 3 OF 5

CREATE BACK-DAM OR SLOPE TO DIRECT ANY WATER THAT DRAINS TO THE SILL AREA OUTWARD AND ONTO THE DRAINAGE PLANE (HOUSEWRAP)

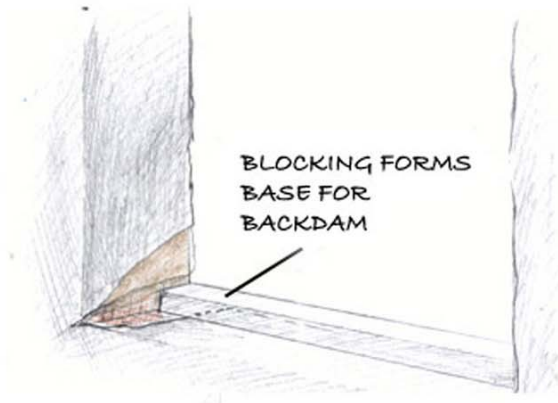

OR

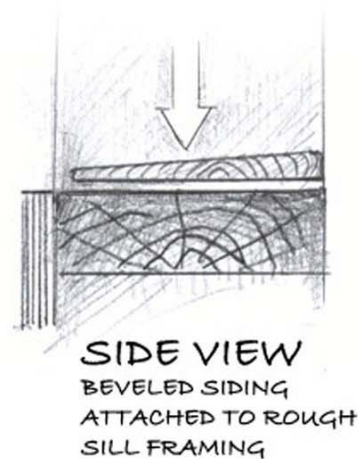

STEP 3 - CREATE BACK DAM OR SLOPE

Flashings and Integration with AB/WRB

EPA Indoor airPLUS | MOISTURE CONTROL 1.6

www.epa.gov/indoorairplus

STEP 4 OF 5 OPTION 1

SELF-ADHESIVE MEMBRANE APPLIED TO SILL AREA, CREATING "PAN FLASHING"
WHICH LAPS OVER AND ADHERES TO DRAINAGE PLANE

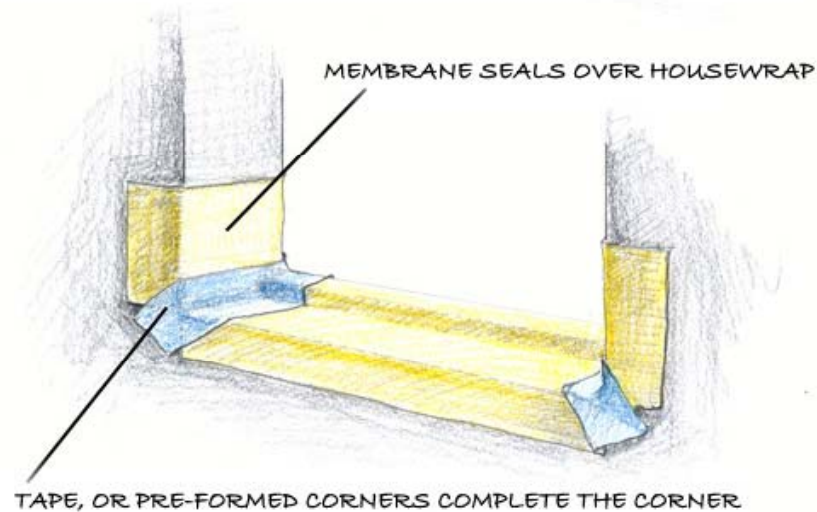

STEP 4 - INSTALL PAN FLASHING- (OPTION 1 OF 2)
SELF-ADHESIVE MEMBRANE "PAN"

Flashings and Integration with AB/WRB

EPA Indoor airPLUS | MOISTURE CONTROL 1.6
www.epa.gov/indoorairplus

STEP 5 OF 5

WINDOW PLACED IN WALL OPENING

A: WINDOW INSTALLED,
RESTING ON PAN FLASHING

B: VERTICAL "SIDE-LEGS" OF
MEMBRANE FLASHING TAPE
SEAL OVER SIDE FLANGES
OF WINDOW UNIT

C: TAPE AT TOP OF WINDOW
COVERS SIDE-LEGS

D: HOUSEWRAP "FLAP"
LOWERED TO COVER TOP
TAPE AND SECURED WITH
TAPE AT CORNERS

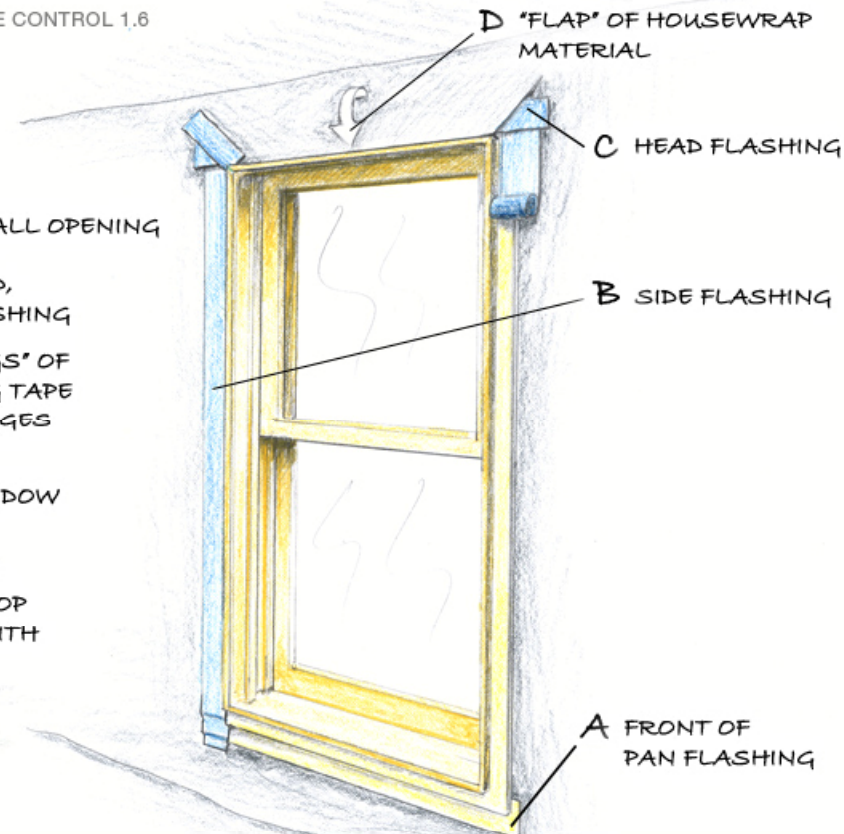

STEP 5 - FINISHING WINDOW INSTALLATION

Building Envelope 101

- Look at the building enclosure as a whole
- Focus on assemblies and systems, rather than single components
- Building Physics do not change, only how we design and build
- Details, Details and more details (drawings/specs)
- Focus on doing it right the first time
- Be a leader in the new era of energy efficiency

Building Envelope 101

- Resources:
 - Building Science.com
 - National Research Council (www.nrc-cnrc.gc.ca)
 - Air Barrier Association of America (airbarrier.org)
 - National Air Barrier Association (www.naba.ca)
 - Canadian Construction Materials Center (www.nrc.ca/ccmc)
 - Green Building Advisor (www.greenbuildingadvisor.com)
 - Canada Mortgage and Housing Corp (www.cmhc-schl.ca.ca)